

Effect of plasma treatment on thermal stability and magnetic properties of Nd-Fe-B series plastic magnets

M. HIGUCHI, M. TSUCHIDA, Z. OSAWA
Faculty of Engineering, Gunma University, Kiryu, Gunma 376, Japan

In order to improve the thermal oxidative stability of the neodymium series ($\text{Nd}_2\text{Fe}_{14}\text{B}$) magnetic powder, plasma polymerization of benzene, styrene and acrylonitrile on the powder was carried out and its effect was examined. A strong hydrophobicity was revealed on the surface of the magnetic powder by the plasma treatment, and the thermal oxidative stability and magnetic properties of the powder were remarkably improved. Magnetic properties of the plastic magnets prepared with the magnetic powder coated with plasma polymer of acrylonitrile on the surface, were superior to plastic magnets prepared with untreated powder.

1. Introduction

Plastic magnets composed of polymer matrices and magnetic powders have been widely used in various fields and have played very important roles in the rapid development of electronic, communication instruments and so on. They have various advantages in productivity and processability, though their magnetic properties are inferior to the more general sintered magnets. Among the rare-earth-Fe series plastic magnets which are extremely superior to the ferrite series, special attention has been paid recently to the Nd-Fe-B series, because of the shortage of samarium (Sm) and cobalt (Co) resources [1-6]. However, the Nd-Fe-B series magnetic powder oxidizes easily losing their magnetic properties [7-9].

In a previous paper [10], we examined the thermal oxidative behaviour of Nd-Fe-B series magnetic powder and observed that the surface treatment of the powder was effective in the prevention of oxidation, especially treatment with PAN and provided thermally stable plastic magnets. Therefore, in the present work, plasma polymerization of benzene, styrene and acrylonitrile was performed to modify the surface properties of the magnetic powder [11, 12]. Then, the effect of surface treatment on the surface properties and thermal oxidative stability of the powder was examined. In addition, the magnetic properties of the powder and plastic magnets prepared with the powder and epoxy resin were evaluated.

2. Experimental procedure

2.1. Materials

The magnetic powder having with main component of $\text{Nd}_2\text{Fe}_{14}\text{B}$ was kindly supplied by the Dai-ichi Kasei Co. Ltd., Japan and had an average particle size of approximately $6.3 \mu\text{m}$. The magnetic powder was kept in cyclohexane under argon (Ar) gas and removed for use in the necessary amount each time.

Acrylonitrile (AN), styrene (ST) and benzene (BZ) monomers were used after conventional distillation. The matrix polymer used was epoxy resin for plastic magnets.

2.2. Plasma treatment

Plasma polymerization of each monomer was carried out with a plasma generator for powdery samples of the Samco International Co. Ltd (see Fig. 1). The magnetic powder (15 g) and agitating glass beads (50 g, diameter 5 mm) were added to a 200 ml round-bottomed reaction vessel. After the pressure of the vessel was reduced to 0.05 torr (1 torr = 133.322 Pa), each monomer was introduced into it until the inner pressure became 0.2 torr. The pressure was then adjusted to 0.3 torr by introducing argon gas, and plasma polymerization was carried out under the following

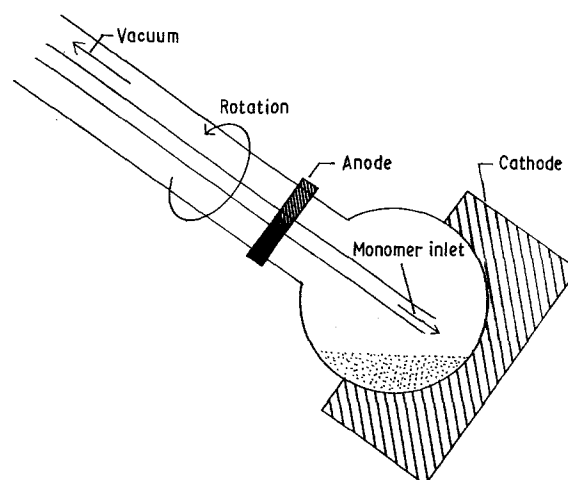

Figure 1 Schematic illustration of plasma treatment for powdery samples.

conditions: power 50 W, 180 mA; time 20 min; rate of rotation 30 r.p.m.

2.3. Preparation of plastic magnets

A mixture of epoxy resin (5.2 g) and magnetic powder (5 g) was added to a cylindrical press with heating facility, and heated at 150 °C for 1 h; disc-like samples (diameter 15 mm, height 10 mm) were obtained. The magnetic powder content in the plastic magnets was 12 vol % (49 wt %).

2.4. Measurement

2.4.1. Thermal oxidative behaviour

Thermal oxidative behaviour of the magnetic powder was recorded on a thermal analyser, Rigaku Denki DTA-TG 8110, using a 10 mg sample, rate of increasing temperature 5 °C min⁻¹, and an 80 ml min⁻¹ air flow.

2.4.2. Surface observation of magnetic powder

The surface of the magnetic powder treated with AN, ST and BZ plasma was observed with a scanning electron microscope JSM-T 20.

2.4.3. Determination of surface properties

In general, measurement of the contact angle gives useful information concerning the surface properties of the materials. However, conventional liquid-drop methods cannot be applied for powdery samples such as this magnetic powder. Therefore, measurement of wettability of a powder with various solvents developed by Bruil and Aartsen [13] was applied. According to this method, affinity between powder and a solvent can be estimated from the penetration height of the solvent into the powder and the time, which is given by Washburn's equation [14]

$$\frac{L_H^2}{t} = \frac{r_p \gamma_L \cos \theta}{2 \mu_L} \quad (1)$$

where L_H is the penetration height of the solvent, t the penetration time, r_p the radius of the capillary (cm), γ_L the surface tension of the solvent (dyn cm⁻¹), μ_L the viscosity of the solvent (g cm⁻¹ s⁻¹), and θ the contact angle between powder and solvent. L_H is proportional to the weight of penetrated solvent, W_L ,

$$L_H = \frac{W_L}{S \varepsilon \rho_L} \quad (2)$$

where S is the cross-sectional area of the measuring column (cm²), ρ_L the density of the solvent (g cm⁻³), and ε the vacant space ratio shown in Equation 3

$$\varepsilon = 1 - (W_p / \rho_p S L_p) \quad (3)$$

where W_p is the weight of the sample (g), ρ_p the density of the sample (g cm⁻³), and L_p the height of the sample (cm). From Equations 1 and 2, the relation between the weight of the penetrated solvent, W_L , and

time, t , can be shown by

$$\frac{W_L^2}{t} = \frac{(S \varepsilon \rho_L)^2 r_p \gamma_L \cos \theta}{2 \mu_L} \quad (4)$$

In this work, water as a hydrophilic solvent, and *n*-octane and carbon tetrachloride as hydrophobic solvents, were used (see Table I) and measurements were carried out on the apparatus shown in Fig. 2.

2.4.4. Magnetic properties

Magnetic properties of the powder and plastic magnets were recorded on a vibrating magnetic power

TABLE I Physical constants of various solvents at 20 °C

Solvent	Viscosity (10 ³ g cm ⁻¹ s ⁻¹)	Density (g cm ⁻³)	Surface tension (dyn cm ⁻¹)
<i>n</i> -octane	5.47	0.703	21.7
Water	10.02	0.998	72.6
Carbon tetrachloride	9.79	1.594	26.9

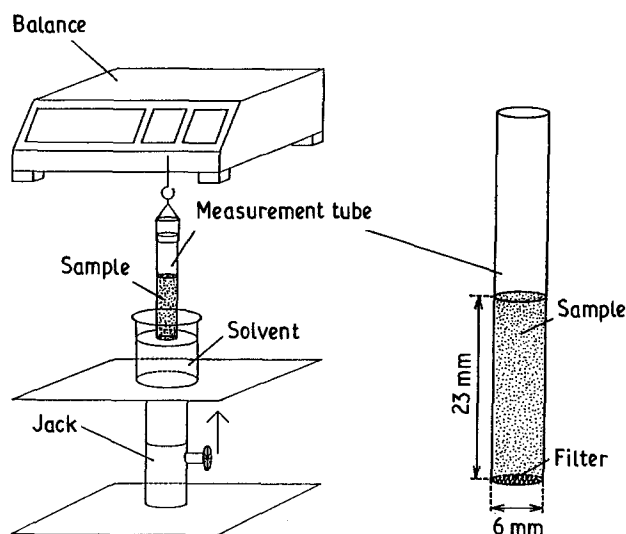

Figure 2 Schematic illustration of the measurement of wettability between magnetic powder and solvent.

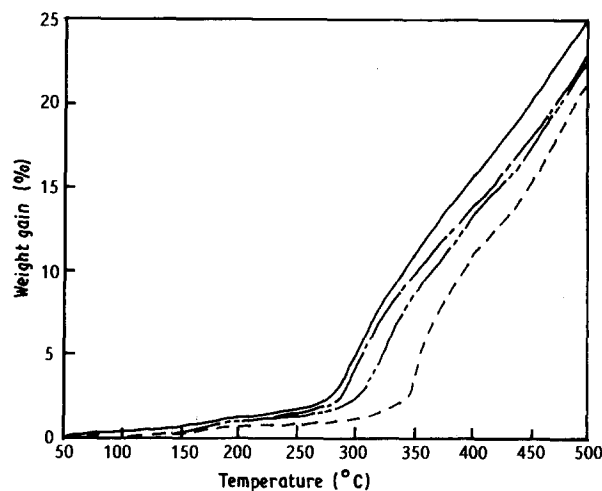

Figure 3 TG curves of magnetic powders treated with various plasmas: (—) no treatment, (---) BZ plasma, (-·-·) ST plasma, (- - -) AN plasma.

measurement apparatus (Riken Electronic, BHV-50 and BHH-50) at room temperature in a fixed external magnetic field (15 kOe). The plastic magnets were pre-magnetized at 30 kOe.

3. Results and discussion

3.1. Thermal stability of the magnetic powder

The effect of surface coating of the $\text{Nd}_2\text{Fe}_{14}\text{B}$ series magnetic powder through plasma polymerization of acrylonitrile (AN), styrene (ST) and benzene (BZ) on the thermal oxidative stability was examined by thermogravimetry (TG). TG curves shown in Fig. 3 indicate that an increase in the weight of the powder due to oxidation starts at about 100°C and proceeds gradually and then suddenly at about 280°C in the untreated series. However, the bending temperature is apparently shifted to the higher side by the plasma polymerization of organic monomers on the surface of the powder: namely, about 290°C in the benzene series, about 300°C in the styrene series and about 340°C in acrylonitrile. Among the three monomers examined, acrylonitrile is found to be the most effective.

3.2. Surface properties

As shown in representative scanning electron micrographs of the magnetic powder, the smooth surface of

the magnetic powder changes to a pleated surface on plasma polymerization of the organic monomers, indicating the formation of a coated membrane on the surface of the powder (see Fig. 4).

In order to examine the surface properties of the powder, W_L^2 values of each series were plotted against immersion time in different solvents, and are shown separately in Figs 5–7.

When carbon tetrachloride was used as a penetration solvent, a slight difference between untreated and plasma-treated samples was observed. In the case of the *n*-octane series, the W_L^2 values of the AN plasma-treated powder were almost twice that of the others, indicating that the surface of the powder became hydrophobic. However, no appreciable difference in the values is observed between BZ and ST plasma-treated powder and the untreated one.

When water is used as a penetration solvent, a remarkable difference in W_L^2 values was observed between the untreated and plasma-treated powder (see Fig. 7). The W_L^2 values of the untreated powder are very much higher than that of the plasma-treated series, indicating that the surface of the untreated powders provides hydrophilic properties.

From these figures, slope values (W_L^2/t) were determined; these are given in Table II. From the values, decreasing affinitive orders of the magnetic powder to *n*-octane and water can be estimated:

for *n*-octane: AN plasma treatment \gg no treatment

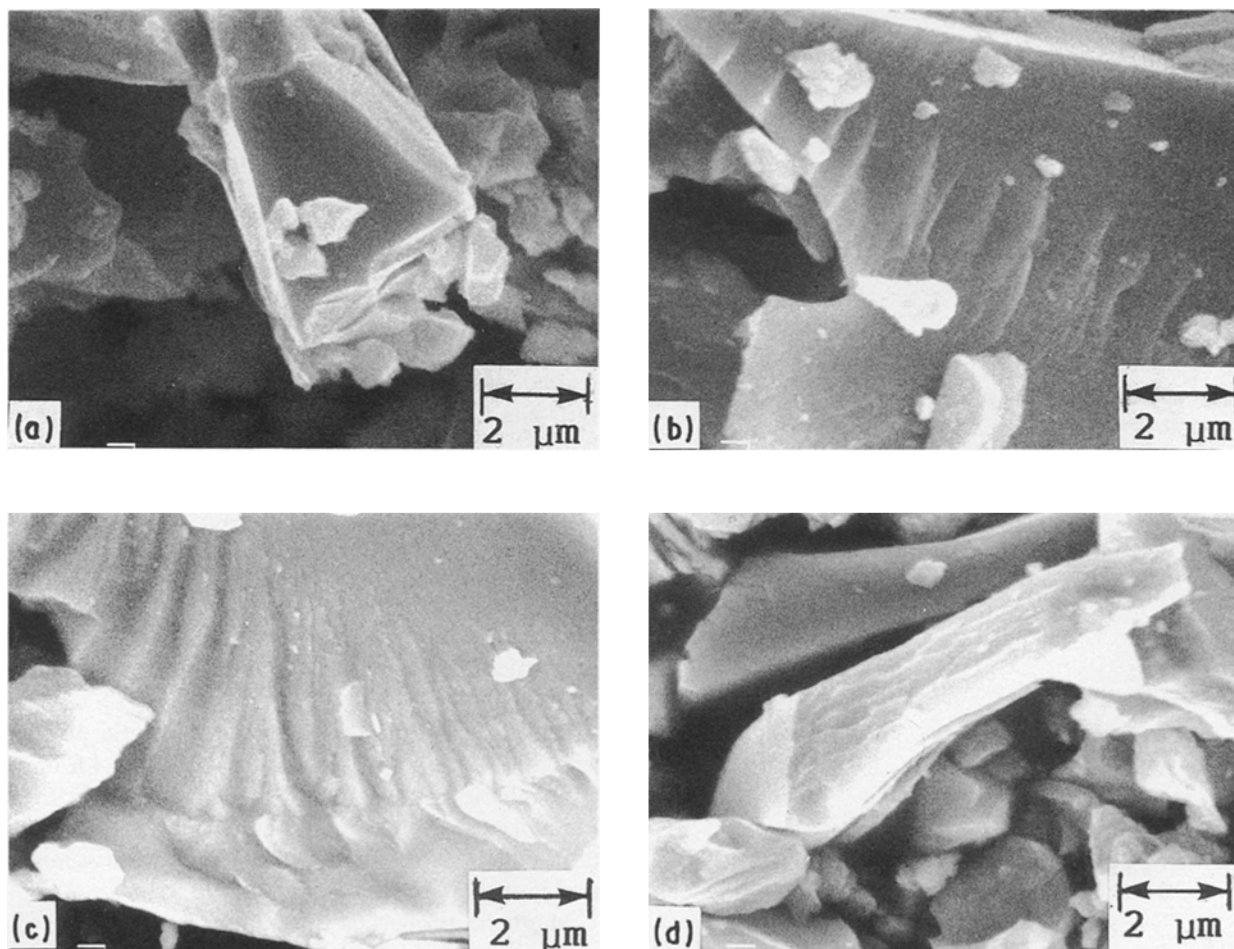

Figure 4 Scanning electron micrographs of magnetic powders. (a) No treatment, (b) AN plasma, (c) ST plasma, (d) BZ plasma.

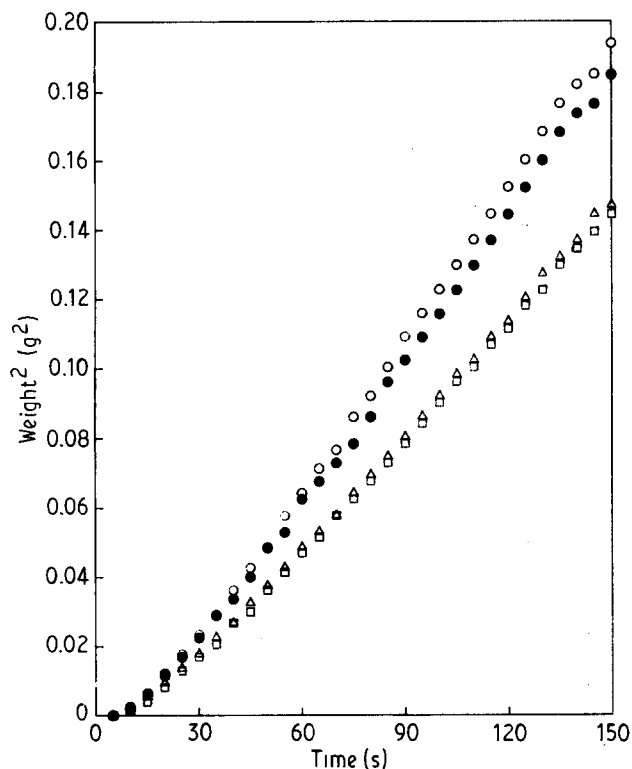

Figure 5 Wettability of magnetic powders with carbon tetrachloride: (○) no treatment, (●) AN plasma, (□) ST plasma, (△) BZ plasma.

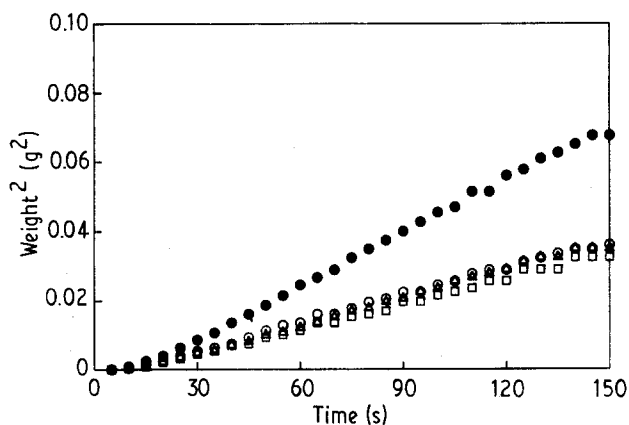

Figure 6 Wettability of magnetic powders with *n*-octane: (○) no treatment, (●) AN plasma, (□) ST plasma, (△) BZ plasma.

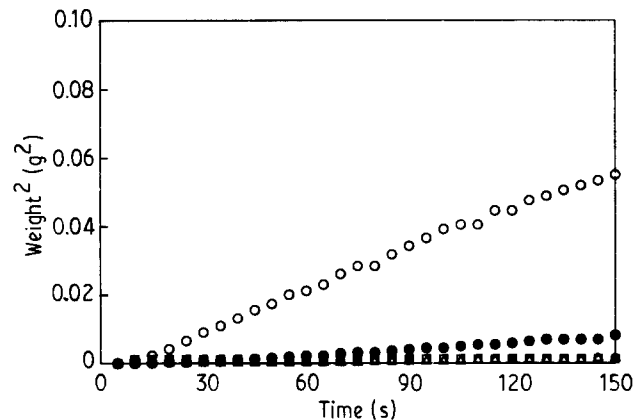

Figure 7 Wettability of magnetic powders with water: (○) no treatment, (●) AN plasma, (□) ST plasma, (△) BZ plasma.

TABLE II W_L^2/t values

Plasma treatment	<i>n</i> -C ₈ H ₁₀ ($\times 10^4$)	H ₂ O ($\times 10^4$)	CCl ₄ ($\times 10^4$)
No treatment	2.64	3.97	14.05
AN	5.02	0.57	13.32
ST	2.40	0.03	11.10
BZ	2.65	0.08	10.59

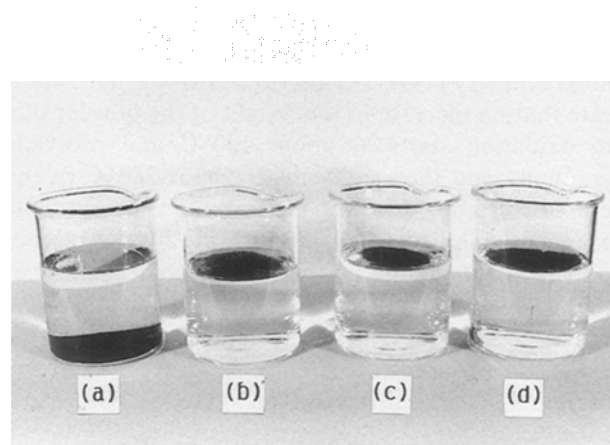

Figure 8 Demonstration of wettability of magnetic powders with water: (a) no treatment, (b) AN plasma, (c) ST plasma, (d) BZ plasma.

= BZ plasma treatment > ST plasma treatment

For water: no treatment \gg AN plasma treatment
> BZ plasma treatment > ST plasma treatment

The results indicate that AN plasma treatment of the magnetic powder increases its affinity to *n*-octane (hydrophobic), while BZ and ST plasma treatments seem to be effective in decreasing hydrophilic properties of the powder rather than increasing its hydrophobic properties.

Dramatic changes in the surface properties of the magnetic powder by these plasmas can be demonstrated when immersing the powder into water. As shown in Fig. 8, untreated powder rapidly sinks to the bottom of a beaker containing water, while surprisingly all powders treated with organic plasma float on top of the water.

3.3. Magnetic properties

The effect of the plasma treatment on the magnetic properties of the powder and plastic magnets was examined.

Demagnetization curves of the magnetic powders which were thermally treated at 100°C for 1 h under atmospheric conditions are shown in Fig. 9. From Fig. 9, coercivity, residual magnetization and saturation magnetization were estimated and are summarized in Table III.

Magnetic properties of the untreated powder decrease remarkably on thermal treatment. For example, the coercivity of 7.77 kOe drops to 6.78 kOe

TABLE III Magnetic properties of magnetic powders

Plasma treatment	Coercivity (kOe)	Residual magnetization (kG)	Saturation magnetization (kG)
Before thermal treatment			
no treatment	7.77	7.54	10.47
After thermal ^a treatment			
No treatment	6.78	6.34	9.09
AN	7.44	7.20	10.07
ST	7.29	6.79	9.91
BZ	7.20	6.77	9.68

^a100 °C, 1 h.

Figure 9 Demagnetization curves of magnetic powders: before thermal treatment, (—) no treatment; after thermal treatment, (...) no treatment, (---) AN plasma, (-·-·) ST plasma, (-·-·) BZ plasma.

and the residual demagnetization of 7.54 kG drops to 6.34 kG. However, the deterioration of the magnetic properties of the powder is appreciably protected by the plasma treatment, and AN plasma treatment, especially, is found to be very effective.

Finally, plastic magnets were prepared with untreated and AN plasma-treated $\text{Nd}_2\text{Fe}_{14}\text{B}$ powders and epoxy resin, and their magnetic properties were evaluated.

Demagnetization curves are shown in Fig. 10. Coercivity and residual magnetization values estimated from Fig. 10 are shown in Table IV. It is clear that the magnetic properties of the plastic magnet prepared with AN plasma-treated powder are superior to those of the plastic magnet prepared with untreated powder, that is, the coercivity and residual magnetization values of the plastic magnet prepared with AN plasma-treated powder are 0.93 kG, and 11.7 kOe, respectively, while the values for the plastic magnet prepared with untreated powder are 0.84 kG and 9.6 kOe, respectively.

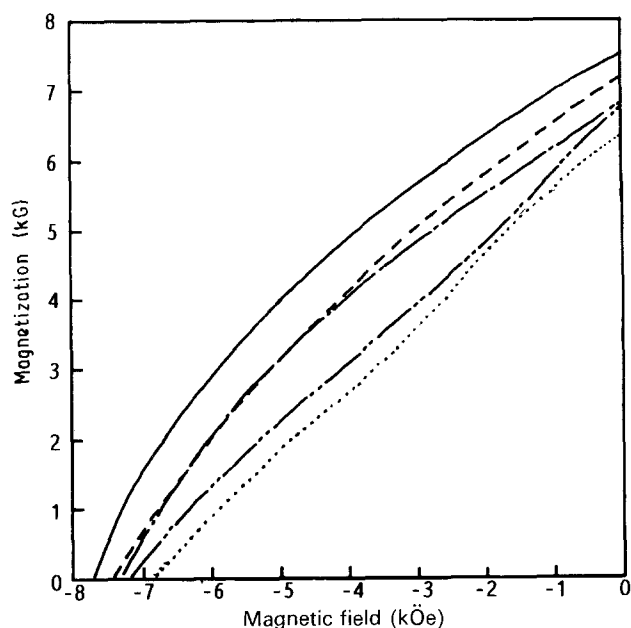
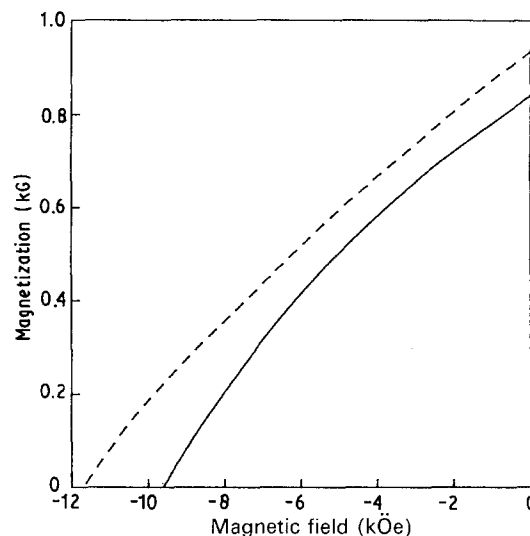

Figure 10 Magnetic properties of plastic magnets: (—) no treatment, (---) AN plasma.

TABLE IV Magnetic properties of plastic magnets

Plasma treatment	Coercivity (kOe)	Residual magnetization (kG)
No treatment	9.6	0.84
AN	11.7	0.93

The results obtained in this work apparently indicate that plasma polymerization of benzene (BZ), styrene (ST) and acrylonitrile (AN) on the magnetic powder remarkably modifies its surface properties, and the thermal oxidative stability and magnetic properties of the powder were improved remarkably. In addition, magnetic properties of the plastic magnets prepared with the magnetic powder treated with acrylonitrile (AN) plasma were superior to the magnetic properties of plastic magnets prepared with untreated powder.

References

1. J. J. CROAT, J. F. HERBEST, R. W. LEE and F. E. PINKERTON, *Appl. Phys. Lett.* **44** (1984) 148.

2. M. SAGAWA, S. FUJIMURA, N. TOGAWA, H. YAMAMOTO and Y. MATSUURA, *J. Appl. Phys.* **55** (1984) 2083.
3. J. D. LIVINGSTON, *ibid.* **57** (1985) 4137.
4. H. H. STADELMAIER and N. C. LIU, *Mater. Lett.* **4** (1986) 304.
5. G. C. HADJIPANAYIS and C. N. CHRISTODOULOU, *J. Magn. Magn. Mater.* **71** (1988) 235.
6. A. FUKUNO and R. C. O'HANDLEY, *IEEE Trans. Magn.* **26** (1990) 250.
7. C. N. CHRISTODOULOU and J. SCHLUP, *J. Appl. Phys.* **61** (1987) 3760.
8. J. JACOBSON and A. KIM, *ibid.* **61** (1987) 3763.
9. A. S. KIM and J. M. JACOBSON, *IEEE Trans. Magn.* **23** (1987) 2509.
10. Z. OSAWA, M. HIGUCHI and S. HINOHARA, *J. Mater. Sci.* **27** (1992) in press.
11. J. F. HERBEST, J. J. CROAT and F. E. PINKERTON, *Phys. Rev. B* **29** (1984) 4176.
12. K. HOZEKI, K. KITAMURA and T. KITADE, *Nippon Kagaku Kaishi* **10** (1984) 1558.
13. H. G. BRUILL and J. J. VAN AARTSEN, *Colloid Polym. Sci.* **252** (1974) 32.
14. EDWARD W. WASHBURN, *Phys. Rev.* **17** (1921) 273.

*Received 29 July
and accepted 25 November 1991*